

WifibOT Lab

Robot WIFIBOT Lab

- High mobility 4x4 platform (2 Wheels possible)
- Modular and open architecture
- Fully controllable using RS232 or Wifi
- Embedded PC with Xpe or Linux Xubuntu

Wifibot Lab is suited for those who want an affordable mobile platform for developing and learning robotics. The base system is composed by a four wheel drive chassis controllable using RS232, 2 infrared sensors, a pan&tilt camera, a mini-pci WIFI card, an Intel Atom D510 duo core SBC running Windows Xpe (or Linux Ubuntu) installed on a 4G compact flash, and a WIFI access point.

You can also connect as option, devices such as Firewire or IP camera (MJPEG or MPEG), GPS, RS232 robotic arm, phidgets usb modules, Hokuyo Lidar or different kind of custom electronic boards like analogue multi camera mini-pci H264 card etc...

You can develop your application on the robot or remotely using the VGA/DVI port or remote desktop via WIFI.

For controlling this robot, several GUI and API are available for PDA and PC. The motor board can be programmed using MPLAD/ICD2/3 debugger or using the internal bootloader.

The RS232 protocol is simple and it can be used with any kind of framework (RTMAPS, URBI, Matlab, etc...)



Option



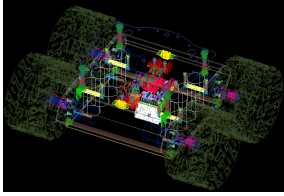

WifibOT Lab

Default Specifications

<i>Motor sensor :</i>	2 hall effect coders 2048 tics / wheel turn
<i>Speed control :</i>	2 x PID DSPIC Microchip 33f coded in C ICD2/3 (option)
<i>Motors :</i>	4x 12v motors 52:1 planetary gear 156 rpm
<i>Dimensions:</i>	L : 30 cm W : 35 cm H : 15 cm W : 3.5Kg
<i>Batteries:</i>	12V NiMh (LIFE 12V possible) 9000 mAH Charger 12V/220V Path Power Management for 2 DC Input Jack : CHARGE + DC 14-15V
<i>Control bus :</i>	RS232. Simple protocol C/C++ API, (MatLab, RTMAPS, Robotics Studio, URBI ... possible)
<i>Distant Protocol :</i>	Sockets TCP/UDP via WIFI or RJ45
<i>CPU :</i>	Intel Atom D510 duo core SBC 1.6Ghz 1G Ram / 4G CF 4 x USB 2.0 4 x RS232/485 1 x Mini-Pci + 1 mini pcie ...
<i>Sensors :</i>	2 Infrared 1 web cam Pan &Tilt 1 Lidar Hokuyo 4m in option
<i>Logiciels:</i>	C++ control API 2 HMI Embedded Web Server

High level Architecture

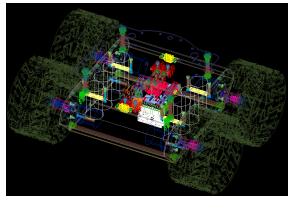

WifibOT Lab

WIFI



Mini-PCI

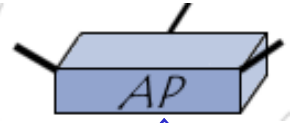

Ethernet

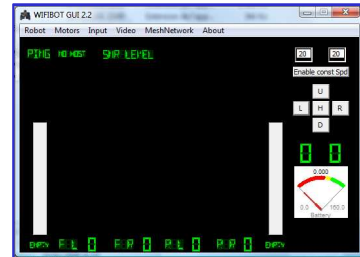

Remote HMI



Embedded CPU

USB

USB

RS232

MJPEG Web Server



ICD2-3 (option)



Camera



4m Lidar

Option

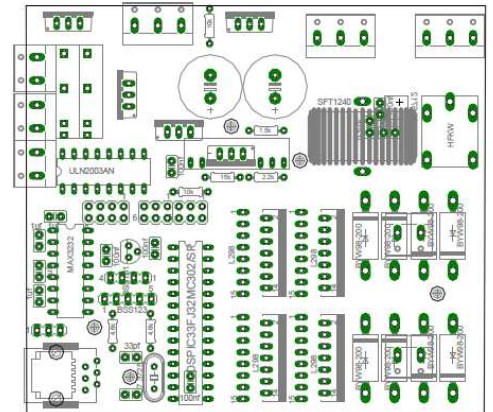

DSPIC 33F Motor Board

Analog

PWM

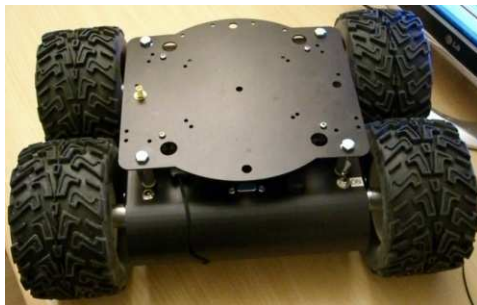

2 x IR Sensors



Motor + Hall Coder

Low Level Architecture

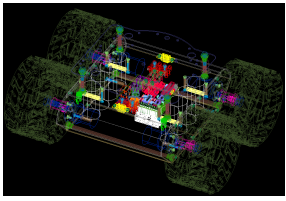

WifibOT Lab

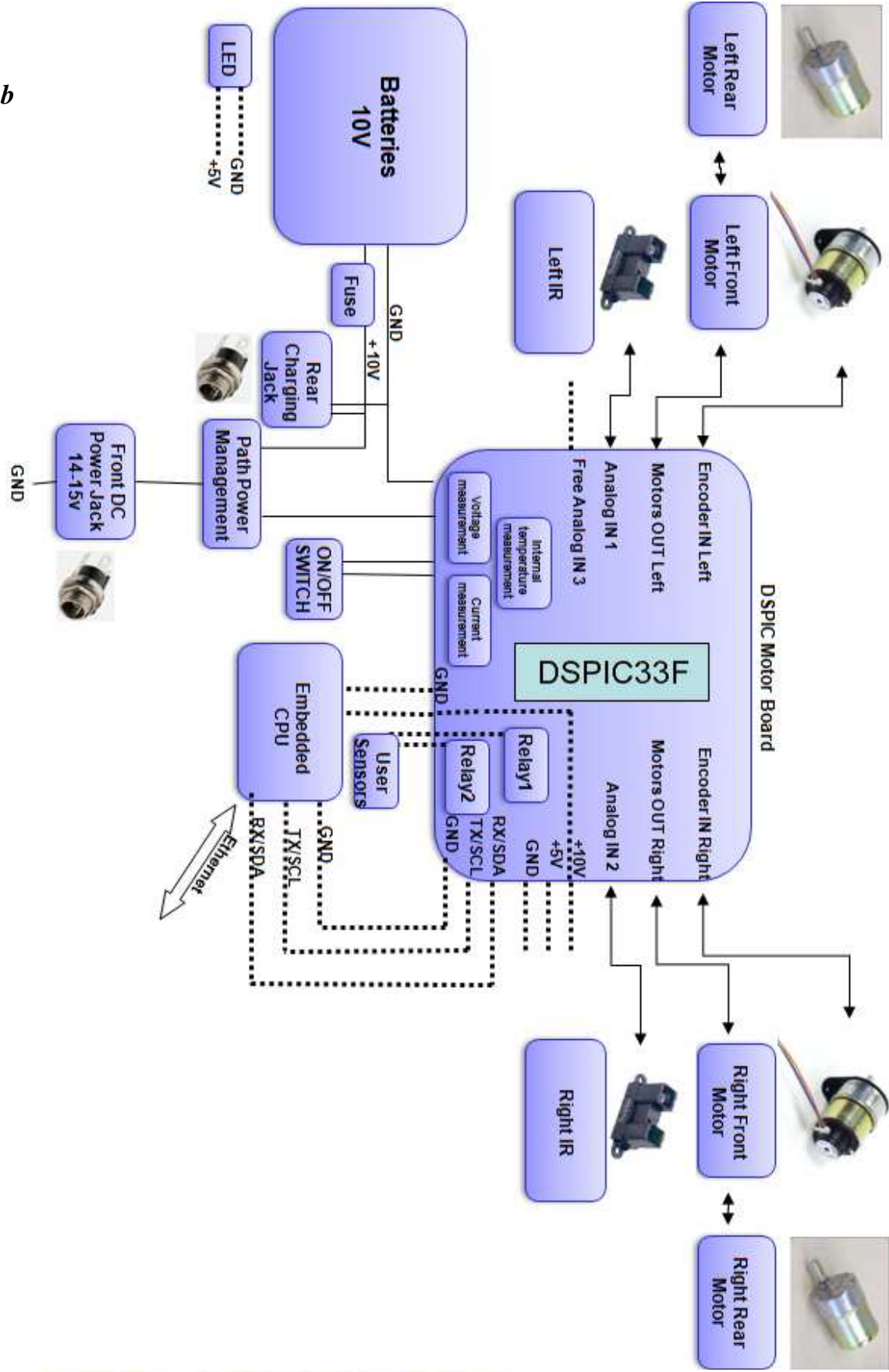

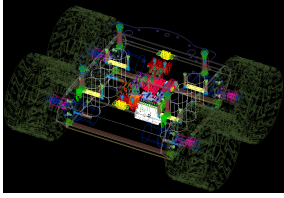

WifibOT Lab

Annexe 1

EMBEDDED CPU



LE-376

3.5" embedded board with Intel® Atom™ dual-core Solution

LE-376 consists of the 13W Intel ATOM D510 and ICH8M, Graphic Processing Unit features power-efficient 32-bit 3D graphics core based on Intel GMA 3150 architecture, video capability with up to 384MB of shared graphics memory, delivers sophisticated graphics for large display applications and with Dual display types such as VGA+LVDS, Enables smoother playback for MPEG-2 codec, a standard video compression format used on Blu-ray, DVDs, broadcasting, and broadband content.

Specification

Form Factor	3.5" embedded board
CPU	Intel® Atom™ D510, 1.66GHz, 1MB cache (LE-376A) Package type : Micro-FCBGA (FCBGA559)
Memory	1 x 200-pin DDR2-667 SO-DIMM up to 4GB (LE-376H/A) Support Non-ECC, unbuffered memory only
Chipset	Intel® ICH8M
Real Time Clock	Chipset integrated RTC with onboard lithium battery
Watchdog Timer	Generates a system reset internal timer for 1min/sec ~ 255min/sec
Power Management	ACPI 2.0 compliant, supports power saving mode
Integrated Graphics	Intel® integrated extreme GMA 3150 Technology
Video Memory	Up to 384MB shared with system memory
LVDS Interface	Chipset Integrated 18-bit single channel LVDS
Serial ATA Interface	2 x SATAII interface with 300MB/s transfer rate
Solid State Disk	1 x Compact Flash Type-II
Audio Interface	Intel® ICH8M integrated with Realtek ALC888 HD Codec
LAN Interface	3 x Intel® 82583V Gigabit Ethernet controller
Expansion Interface	1 x PCIe mini card & 1 x Mini-PCI socket
Internal I/O Port	1 x Audio, 4 x USB2.0, 1 x LVDS, 1 x LCD Inverter, 1 x LPT 1 x RS232/4224/5, 4 x RS232, 1 x SMBUS, 1 x IrDA
External I/O Port	1 x USB, 3 x RJ45 LAN, 1 x DB15 VGA, 1 x RS232
Power Requirement	DC 9V ~ 24V input



Annexe 2

WLAN 802.11a/b/g mini-PCI Module

DCMA-81

SPECIFICATION

Frequency Band	<ul style="list-style-type: none"> ➤ 2.312 – 2.472GHz, 2.484 GHz ➤ U-NII: 5.15 - 5.35GHz, 5.725 - 5.825GHz ➤ ISM: 5.725 – 5.850 GHz ➤ DSRC: 5.850 – 5.925 GHz ➤ Europe: 5.15 - 5.35GHz, 5.47 - 5.725GHz ➤ Japan: 4.90 – 5.00GHz, 5.03 – 5.091GHz, 5.15 – 5.35GHz
Modulation technique	<ul style="list-style-type: none"> ➤ 802.11 a/b/g DSSS (DBPSK, DQPSK, CCK) OFDM (BPSK, QPSK, 16-QAM, 64-QAM)
Host interface	Half size Mini PCI Type 3A
Channels support	<ul style="list-style-type: none"> ➤ 802.11b/g US/Canada: 11 (1 ~ 11) Major European country: 13 (1 ~ 13) France: 4 (10 ~ 13) Japan: 11b: 14 (1~13 or 14th), 11g: 13 (1 ~ 13) ➤ 802.11a US/Canada: 12 non-overlapping channels Europe: 19 non-overlapping channel Japan: 4 non-overlapping channels

Output power	<ul style="list-style-type: none"> ➤ A Mode: +17dBm at 6, 9, 12, 18, and 24Mbps +16dBm at 36Mbps +14dBm at 48Mbps +13dBm at 54Mbps ➤ B Mode: +19dBm at 1,2, 5.5, and 11Mbps ➤ G Mode: +17dBm at 6, 9, 12, 18, 24 and 36Mbps +16dBm at 48Mbps +15dBm at 54Mbps
Operation distance	<ul style="list-style-type: none"> ➤ 802.11a: Outdoor: 85m@54Mbps, 250m@6Mbps Indoor: 20m@54Mbps, 40m@6Mbps ➤ 802.11b: Outdoor: 250m@11Mbps, 300m@1Mbps Indoor: 30m@11Mbps, 50m@1Mbps ➤ 802.11g: Outdoor: 80m@54Mbps, 250m@6Mbps Indoor: 15m@54Mbps, 35m@6Mbps
Operation System supported	➤ Windows® 2K, XP
Dimension	➤ 59.75mm(L) * 25.50mm (W) * 5mm (H)
Security	<ul style="list-style-type: none"> ➤ 64-bit, 128-bit, 152-bit WEP Encryption ➤ 802.1x Authentication ➤ AES-CCM & TKIP Encryption
Operation mode	➤ Infrastructure & Ad-hoc mode
Operation temperature	➤ 0°C ~ 70°C
Storage temperature	➤ -20°C ~ 70°C

Annexe 3

108M Wireless Access Point TL-WA601G



Specifications:

Standards	IEEE 802.11g, IEEE 802.11b
Interface	1 10/100M auto-sensing LAN Port
Wireless Signal Rates With Automatic Fallback	Super G™ : 108M 11g: 54/48/36/24/18/12/9/6M(dynamic) 11b: 11/5.5/2/1M(dynamic)
Frequency Range	2.4-2.4835GHz
Wireless Transmit Power	20dBm(Max)
Antenna	3dBi detachable Omni directional antenna
Modulation Technology	IEEE 802.11b: DQPSK, DBPSK, DSSS, and CCK IEEE 802.11g: BPSK, QPSK, 16QAM, 64QAM, OFDM
Receiver Sensitivity	108M: -68dBm@10% PER 54M: -68dBm@10% PER 11M: -85dBm@8% PER 6M: -88dBm@10% PER 1M: -90dBm@8% PER 256K: -105dBm@8% PER
Power Supply Unit	Input: localized to country of sale Output: 9VAC / 0.8A linear PSU
Operating temperature	0°C~40°C (32°F~104°F)
Storage temperature	-40°C~70°C (-40°F~158°F)
Relative humidity	10% ~ 90%, non condensation
Storage Humidity	5%~95% non-condensing
Dimensions	6.2×4.3×1.3 in. 158×110×32 mm

Annexe 4



Technical Specifications

- Motorized tracking (189° horizontal and 102° vertical)
- Carl Zeiss® optics
- Autofocus lens system
- Ultra-high resolution 2-megapixel sensor with RightLight™ 2 Technology
- Color depth: 24-bit true color
- Video capture: Up to 1600 by 1200 pixels (HD quality)
- Still-image capture: 8 megapixels (with software enhancement)
- Built-in microphone with RightSound™ Technology
- Frame rate: Up to 30 frames per second
- High-Speed USB 2.0
- Logitech QuickCam® software (with Video Effects™, filters, avatars, and face accessories)
- Works with Skype™, Windows Live™ Messenger, Yahoo®, AOL® and other compatible instant messaging applications



Motorized tracking

It keeps you right in the middle of the picture, offering 189-degree field of view and 102-degree tilt.



Carl Zeiss® optics

You'll enjoy razor-sharp images from a lens designed with the help of one of the pioneers in the industry. Find out more about why our collaboration with Carl Zeiss benefits you.

[Learn more.](#)



Advanced autofocus

Your images stay razor sharp, even in close-ups (up to 10 cm from the camera lens) with built-in autofocus. Learn all about Logitech autofocus.

[Learn more.](#)



HD video recording

Your friends and family can see you in widescreen video at HD quality (720p).

2.0 megapixel sensor

Higher-megapixel performance

With its true 2-megapixel sensor, with up to 8-megapixel photos (software enhanced), every video call and photo will look sharp. Megapixels? Sensor? Why is image quality so important?

[Learn more.](#)



RightLight™ 2 technology

Even if you make a video call in dim or poorly backlit settings, the camera will intelligently adjust to produce the best possible image. Find out what's right about RightLight 2 technology.

[Learn more.](#)

Annexe 5

AC/DC Multi-Functional Balance Silent Charger/Discharger

*Chargeur AC/DC Multi-Fonctions
charge/décharge équilibreur silencieux
Avec monitoring USB par PC*



GP2Y0A02YK

Long Distance Measuring Sensor

■ Features

1. Less influence on the colors of reflected objects and their reflectivity, due to optical triangle measuring method
2. Distance output type
(Detection range:20 to 150cm)
3. An external control circuit is not necessary
Output can be connected directly to a microcomputer

■ Applications

1. For detection of human body and various types of objects in home appliances, OA equipment, etc

■ Absolute Maximum Ratings (T_a=25°C)

Parameter	Symbol	Rating	Unit
Supply voltage	V _{CC}	-0.3 to +7	V
*1 Output terminal voltage	V _O	-0.3 to V _{CC} +0.3	V
Operating temperature	T _{opr}	-10 to +60	°C
Storage temperature	T _{stg}	-40 to +70	°C

*1 Open collector output

■ Recommended Operating Conditions

Parameter	Symbol	Rating	Unit
Operating Supply voltage	V _{CC}	4.5 to 5.5	V

Internal Block Diagram

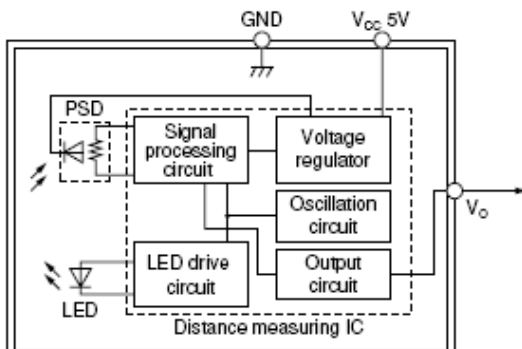

Timing Chart

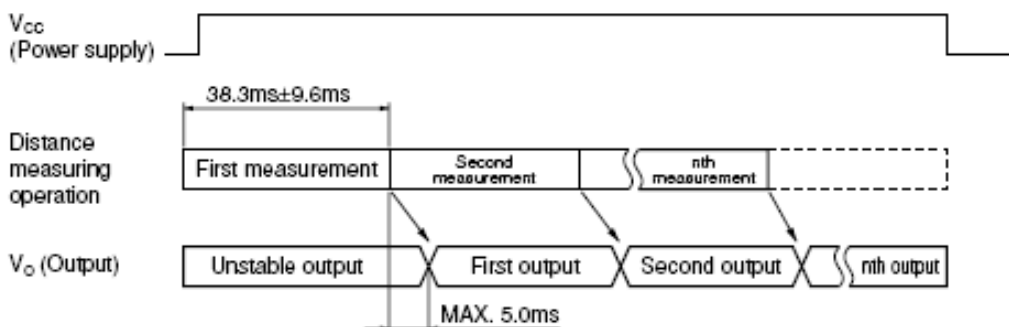

■ Outline Dimensions (Unit : mm)

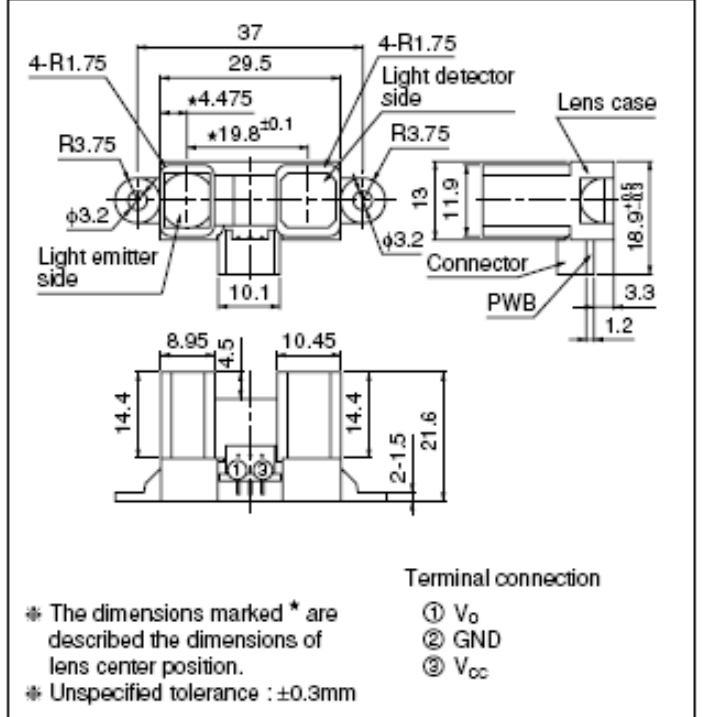

Analog Output Voltage vs. Distance to Reflective Object

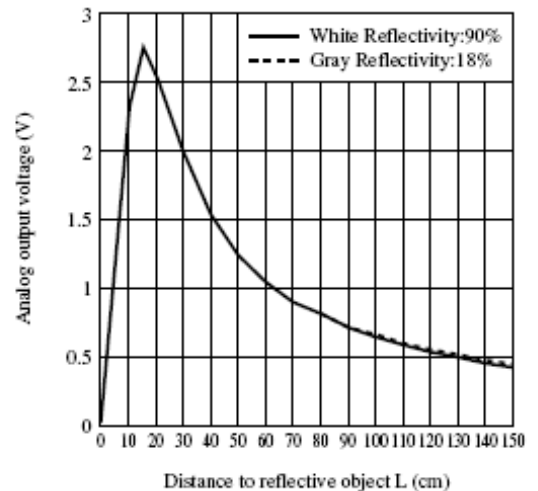

Annexe 7 (Motor 12V 1/51)

Model : PK32F Series of DC Planetary Gear Motor



(A). Dimensional Figures :

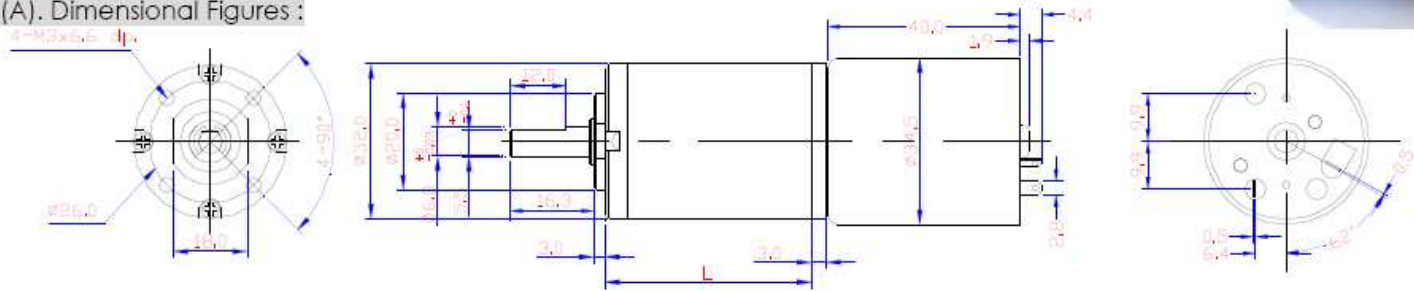

(B). Standard DC Motor Specifications :

DESCRIPTION	Rated Voltage	Speed	Current	Torque	Output	Eff
	VDC	RPM	mA	g-cm	W	%
NO LOAD	12V	6000 ± 600	approx. 136			
	24V	6000 ± 600	approx. 50			
AT MAX. EFF	12V	5000	approx. 710	approx. 105	approx. 5.4	63
	24V	5100	approx. 320	approx. 105	approx. 5.4	71
AT STALL	12V		approx. 3755	approx. 656		
	24V		approx. 2122	approx. 780		

(C). Gearbox Specifications :

Reduction Ratio	Rated Tolerance Torque	Max. Momentary Tolerance Torque	Efficiency	Radial Play of Shaft	Thrust Play of Shaft	L
1/5	2kgf-cm Max	6 kgf-cm	80%	≤ 0.05 mm	≤ 0.03 mm	17.6
1/27	6kgf-cm Max	18 kgf-cm	70%	↑	↑	24.0
1/51, 1/71	12kgf-cm Max	36 kgf-cm	60%	↑	↑	30.4
1/100	12kgf-cm Max	36 kgf-cm	60%	↑	↑	30.4
1/264	12kgf-cm Max	36 kgf-cm	50%	↑	↑	36.8
1/516	12kgf-cm Max	36 kgf-cm	50%	↑	↑	36.8
1/721	12kgf-cm Max	36 kgf-cm	50%	↑	↑	36.8

Model: EM3516 One / Two Channel Hall Effect Encoder

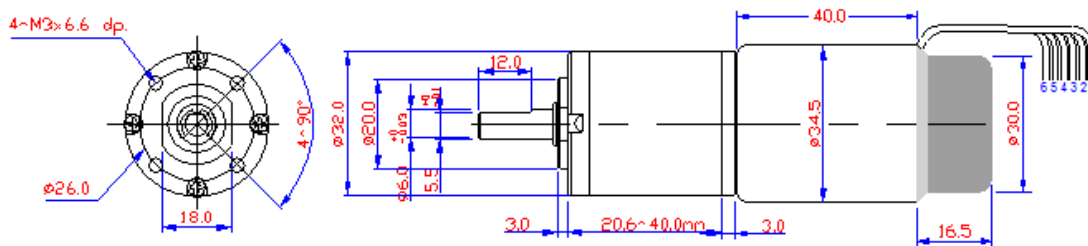

■ **Resolution :** 12 Resolution P/R

■ **Electrical Specifications**

Power Source	4.5 ~ 24VDC
Current Consumption	30mA or below
Response Frequency	20KHz
Output Mode	With pull up resistor
Output Signal	A, A&B

© Please indicate which is the resolution P/R and rotational direction when placing an order.

■ **Feature**

- Hall Effect Sensor
- Speed Position Detection
- Low cost

■ **Output Circuit :**

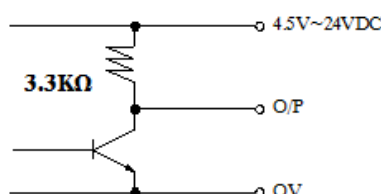

■ **One Channel Encoder Connections :**

1. Black : HALL SENSOR GND
2. Red : HALL SENSOR Vcc
3. White: HALL SENSOR Aout
4. Green: EMPTY
5. Brown: +MOTOR
6. Blue : - MOTOR

■ **Two Channel Encoder Connections :**

1. Black : HALL SENSOR GND
2. Red : HALL SENSOR Vcc
3. White: HALL SENSOR A Vout
4. Green: HALL SENSOR B Vout
5. Brown: +MOTOR
6. Blue : - MOTOR

URG-04LX-UG01

Low Cost Compact LRF from **HOKUYO**

Laser Range Finders (LRF) provide continuous time stamped mapping information.

The URG-04LX-UG01 is the smallest & lightest LRF available. With a single USB connection it is ideally suited to mobile robotic applications

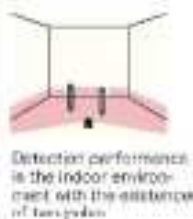

Detection performance in the indoor environment with the assistance of two poles

- 5.6 metres range
- 240° scan 0.35° resolution
- 10 scans per second
- Compact: 50 x 50 x 70mm
- Lightweight 160g
- Low Power 5V DC, 2.5W

Annexe 9 (Option)



MiniStation
World's Smallest WiFi Platform



FREE LINUX SDK

SYSTEM INFORMATION							
Processor Specs	Atheros MIPS 4KC, 180MHz						
Memory Information	16MB SDRAM, 4MB Flash						
Networking Interface	1 X 10/100 BASE-TX (Cat. 5, RJ-45) Ethernet Interface						
REGULATORY / COMPLIANCE INFORMATION							
Wireless Approvals	FCC Part 15.247, IC RS210						
RoHS Compliance	YES						
RADIO OPERATING FREQUENCY 2412-2462 MHz							
TX SPECIFICATIONS			RX SPECIFICATIONS				
802.11b	DataRate	TX Power	Tolerance	802.11b	DataRate	Sensitivity	Tolerance
	1Mbps	26 dBm	+/-2dB		1Mbps	-97 dBm	+/-1dB
	2Mbps	26 dBm	+/-2dB		2Mbps	-96 dBm	+/-1dB
	5.5Mbps	26 dBm	+/-2dB		5.5Mbps	-95 dBm	+/-1dB
	11Mbps	26 dBm	+/-2dB		11Mbps	-92 dBm	+/-1dB
802.11g OFDM	6Mbps	26 dBm	+/-2dB	802.11g OFDM	6Mbps	-94 dBm	+/-1dB
	9Mbps	26 dBm	+/-2dB		9Mbps	-93 dBm	+/-1dB
	12Mbps	26 dBm	+/-2dB		12Mbps	-91 dBm	+/-1dB
	18Mbps	26 dBm	+/-2dB		18Mbps	-90 dBm	+/-1dB
	24Mbps	26 dBm	+/-2dB		24Mbps	-86 dBm	+/-1dB
	36Mbps	24 dBm	+/-2dB		36Mbps	-83 dBm	+/-1dB
	48Mbps	22 dBm	+/-2dB		48Mbps	-77 dBm	+/-1dB
	54Mbps	21 dBm	+/-2dB		54Mbps	-74 dBm	+/-1dB
ADJUSTABLE CHANNEL SIZE SUPPORT							
5MHz	10MHz	20MHz	40MHz				
RANGE PERFORMANCE							
Outdoor (Antenna Dependent):	Over 50km						
PHYSICAL / ELECTRICAL / ENVIRONMENTAL							
RF Connector	1xMMCX, 1x integrated PCB printed antenna						
Enclosure Size	5.0.0x2.0x1.2 (cm)						
Max. Power Consumption	5 Watts						
Power Rating	Up to 24V						
Power Method	Passive Power over Ethernet (pairs 4,5+; 7,8 return)						
Operating Temperature	-20C to +70C						
Operating Humidity	5 to 95% Condensing						
Shock and Vibration	ETSI300-019-1.4						
SOFTWARE							

Annexe 10 (Option)

Mini-PCI

MP-323 - Mini-PCI IEEE 1394a Module

Form Factor: Mini-PCI type III B with 124-pin interface.

Controller: Agere FW323.

Output Function: 3 x 8-pin IEEE1394a Connector.

Dimensions: 45mm x 60mm (W x L).

Accessories: 1x 8-pin IEEE 1394a Cable.

Power Requirements: small 4-pin AT power connector for 12V.



MP-840

H.264 Hardware Compression Card with 4 Ports of Video & Audio Inputs



Features

- Mini-PCI interface
- H.264 Hardware Compression
- 4- ch Video & Audio inputs
- Support D1
- Windows XP, Vista (32-bit) SDK & Driver

MP-878D2

2-ch Mini-PCI capture card with Software Develop Kit



Features

- Mini-PCI interface
- 2- ch Video input
- Support D1 , CIF resolution
- Windows Driver & SDK provide
- Linux Driver provide

MP-6100

H.264 Hardware Compression Card with 4 Ports of Video & Audio Inputs



Features

- Mini-PCI interface
- H.264 Hardware Compression
- 4- ch Video & Audio inputs
- Support D1 , CIF
- Windows / Linux SDK & Driver